

# OSP Stage 2040 <Design>

**Project Team**

**T4 Team**

Latest update on:

**2015-04-13**

---

**Team Information**

**박정민 컴퓨터공학부 201111354**

**박준한 컴퓨터공학부 201111356**

**정국빈 컴퓨터공학부 201111384**

## Table of Contents

Activity 2041. Define Real Use Cases.....	3
Activity 2042. Define Reports, UI, and Storyboards.....	9
Activity 2043. Refine System Architecture .....	12
Activity 2044. Define Interaction Diagrams.....	13
Activity 2045. Define Design Class Diagrams .....	22

## Activity 2041. Define Real Use Cases

Use Case	Parent Mode
Actor	User
Purpose	Parent Mode로 들어간다.
Overview	Parent Mode로 들어가 프로그램에 관한 것을 설정한다.
Type	Primary and Real
Cross References	System functions: R1.1, R1.3 Use Case: Parent Mode, Account
Pre-Requisites	N/A
Typical Courses of Events	(A): User / (S): System 1. (A) btnParentMode 클릭 2. (S) Parent.txt의 내용을 temp에 저장 3. (S) checkParentAccount()==true 확인 4. (S) checkPassword(txtPssword.getText(),temp)==true 확인 5. (S) Parent 객체 생성
Alternative Courses of Events	3. false면 return 후 account()
Exceptional Course of Events	4. 틀렸다면 상태유지

Use Case	Account
Actor	User
Purpose	Parent의 비밀번호 및 Child의 이름을 등록한다.
Overview	Parent Mode나 Child Mode를 선택했을 때, User가 등록되어 있지 않다면 Parent의 비밀번호 및 Child의 이름을 등록한다.
Type	Primary and Real
Cross References	System function: R1.3 Use case: Account
Pre-Requisites	N/A
Typical Courses of Events	(P): Parent / (S): System 1. (P) btnAccount 클릭 2. (P) txtPasswrod, txtName에 Password, Name 입력 3. (P) btnAccount 클릭 4. (S) Parent.password = txtPassword.getText()로 설정 5. (S) Parent.txt에 Parent.password 저장 6. (S) Child.name = txtName.getText()로 설정 7. (S) Child.txt에 Child.name 저장
Alternative Courses of Events	N/A
Exceptional Course of Events	N/A

Use Case	Send Message
Actor	Parent
Purpose	Child에게 간단한 Message 보낸다.
Overview	Child가 계속 볼 수 있는 간단한 Message를 설정해 놓는다.
Type	Primary and Real
Cross References	System functions: R2.1 Use case: Send Message
Pre-Requisites	Parent 객체 생성
Typical Courses of Events	(P): Parent / (S): System 1. (P) btnSendMsg 클릭 2. (P) txtMessage에 메시지 입력 3. (S) Superman.setMessasge(txtMessage.getText()) 설정 4. (S) Superman.txt파일에 Superman.message 저장
Alternative Courses of Events	N/A
Exceptional Course of Events	2. Text 내용이 없으면 메시지 출력, 상태유지

Use Case	Goal Setting
Actor	Parent
Purpose	Child에게 일정 목표 및 보상 설정
Overview	Child가 Wordtrain Game을 통해 얻어야 할 일정 Exp를 설정하고 이에 따른 보상 설정
Type	Primary and Real
Cross References	System function: R2.2 Use case: Goal Setting
Pre-Requisites	Parent 객체 생성
Typical Courses of Events	(P): Parent / (S): System 1. (P) btnGoalSetting 클릭 2. (P) txtGoal, txtReward에 Goal, Reward 입력 3. (S) Superman.setGoal(txtGoal.getText())로 재설정 4. (S) Superman.setReward(txtReward.getText())로 재설정 5. (S) Superman.txt에 Superman.goal, Superman.reward 저장
Alternative Courses of Events	N/A
Exceptional Course of Events	N/A

Use Case	Check Goal
Actor	Parent
Purpose	Child의 Goal을 달성했나 확인
Overview	Child가 Parent가 설정해 놓았던 Goal을 얼마나 달성했는지 여부를 봄
Type	Primary and Real
Cross References	System function: R2.3 Use case: check goal
Pre-Requisites	Parent, Superman 객체 생성
Typical Courses of Events	(P): Parent (S): System 1. (P) btnCheckGoal 클릭 2. (S) txtGoal, txtExp 에 Goal, Exp 출력
Alternative Courses of Events	N/A
Exceptional Course of Events	N/A

Use Case	Reset
Actor	Parent
Purpose	모든 정보를 초기화
Overview	Parent를 포함한 Child의 모든 정보 초기화
Type	Primary and Real
Cross References	System function: R2.4 Use Case: Reset
Pre-Requisites	Parent, Superman, Child 객체 생성
Typical Courses of Events	(P): Parent / (S): System 1. (P) btnReset 클릭 2. (S) Parent.reset()실행 3. (S) Paren.txt, Goal.txt, Reward.txt, Child.txt 초기화
Alternative Courses of Events	N/A
Exceptional Course of Events	N/A

Use Case	Child Mode
Actor	User
Purpose	Child Mode로 들어간다
Overview	Wordtrain Game, Practice, Dictionary등을 이용하기 위해 Child Mode로 들어간다.
Type	Primary and Real
Cross References	System function: R1.2, R1.3 Use case: Child Mode
Pre-Requisites	N/A
Typical Courses of Events	(A): User / (S): System 1. (A) btnChildMode 클릭 2. (S) Child.txt의 내용을 temp에 저장 3. (S) checkChildAccount()==true 확인 4. (S) Child 객체 생성
Alternative Courses of Events	3. false면 return 후 account()
Exceptional Course of Events	N/A

Use Case	Print Message
Actor	N/A
Purpose	Parent가 설정해 놓은 Message를 출력
Overview	Child Mode에서 Child가 Parent가 설정해놓은 Message를 볼 수 있게 해준다.
Type	Primary and Real
Cross References	System function: R3.1 Use case: Print Message
Pre-Requisites	Child Mode를 실행한다
Typical Courses of Events	(S): System 1. (S) txtMessage.setText(Superman.getMessage)로 설정
Alternative Courses of Events	N/A
Exceptional Course of Events	N/A

Use Case	Print Goal
Actor	N/A
Purpose	Parent가 설정해 놓은 Goal을 출력
Overview	Child Mode에서 Child가 Parent가 설정해놓은 Goal을 볼 수 있게 해준다.
Type	Primary and Real
Cross References	System function: R3.2 Use case: Print Goal
Pre-Requisites	Child Mode를 실행한다.
Typical Courses of Events	(S): System 1. (S) Superman.goal == "goal"인지 확인 2. (S) lblGoal.setText(Superman.getGoal) 설정 3. (S) lblReward.setText(Superman.getReward) 설정
Alternative Courses of Events	N/A
Exceptional Course of Events	1. "goal"이면 setText(goal_txtfield), setText(rwrdr_txtfield) = " "

Use Case	Print Exp
Actor	N/A
Purpose	Wordtrain Game을 통해 얻은 Exp를 출력
Overview	Wordtrain Game시에 얻은 Exp를 종합해서 총 점수를 계속해서 출력
Type	Primary and Real
Cross References	System function: R3.3 Use case: Print Exp
Pre-Requisites	Child Mode를 실행한다.
Typical Courses of Events	(S): System 1. (S) lblExp.setText(Superman.Exp)로 설정
Alternative Courses of Events	N/A
Exceptional Course of Events	N/A

Use Case	Next Level
Actor	N/A
Purpose	Child가 얻은 Exp가 일정 구간에 도달하면 레벨이 올라간다.
Overview	Child가 Wordtrain Game에서 얻은 Exp가 일정 수준이 되면 레벨이 올라간다.
Type	Primary and Real
Cross References	System function: R3.4 Use case: Next Levels
Pre-Requisites	Child 객체 생성, Child.wordtrainGame()실행 후
Typical Courses of Events	(S): System 1. (S) Child.wordtrainGame() 실행 후, Child.exp 확인 2. (S) Child.getExp % 50 == 0 인지확인 3. (S) Child.level++
Alternative Courses of Events	2. Child.exp%50 != 0 이면 넘어감
Exceptional Course of Events	N/A

Use Case	Wordtrain Practice
Actor	Child
Purpose	Wordtrain Game이전에 끝말잇기 방법이나 단어를 학습한다.
Overview	System에서 미리 5개의 단어와 단어에 해당하는 버튼을 제공해, 버튼을 선택하면서 끝말잇기를 진행하게 한다.
Type	Primary and Real
Cross References	System functions: R3.5 , R4.1, R4.2, R4.3, R4.4, R4.6 Use case: Wordtrain Practice, Print Wordlist, Explain Word, Print Picture, Play Sound
Pre-Requisites	Child Mode를 실행한다.
Typical Courses of Events	(C): Child / (S): System 1. (C) btnWordtrainPractice 클릭 2. (S) printWordList()로 btnWord[3] = wordlist[3] 할당 3. (C) btnWord 클릭 4. (S) explainWord(), printPicture() 실행 5. (C) btnSound 클릭 6. (S) playSound URL경로를 들어가 파일 재생 7. (C) btnNext 클릭 8. (S) Wordtrain.printWortrain(newWord)로 입력했던 Word 추가
Alternative Courses of Events	5. btnSound 클릭 안 할 시 6. 생략
Exceptional Course of Events	N/A

Use Case	Wordtrain Game
Actor	Child
Purpose	영어단어를 이용해 끝말잇기를 해서 점수를 얻음
Overview	영어 단어를 끝말잇기 형식으로 입력해 이어감으로써 목표를 달성할 수 있게 한다.
Type	Primary and Real
Cross References	System function: R3.6, R4.2, R4.3, R4.4, R4.5, R4.6 Use case: Wordtrain Game, Explain Word, Print picture, Play Sound, Print Wordtrain, Check Word
Pre-Requisites	Child Mode를 실행한다.
Typical Courses of Events	(C): Child / (S): System 1. (C) btnWordtrainGame 클릭 2. (S) txtWord에 단어를 입력 받는다. 3. (S) searchWord(newWord)로 Word 객체를 할당 받는다. 4. (S) explainWord(), printPicture() 실행 5. (C) btnSound 클릭 6. (S) playSound URL경로를 들어가 파일 재생 7. (C) btnNext 클릭 8. (S) Wordtrain.printWordtrain(newWord)로 입력했던 Word 추가
Alternative Courses of Events	2. btnExit 클릭 시, child.exp를 update하고 종료 3. 틀렸으면 틀렸다는 메시지 출력 5. btnSound 클릭 안 하면 바로 7.로 넘어감
Exceptional Course of Events	N/A

Use Case	Dictionary
Actor	Child
Purpose	Child가 원하는 단어를 검색하게 해준다.
Overview	Child가 영어단어를 검색해 그 단어에 해당하는 설명 및 그림, 발음을 제공한다.
Type	Primary and Real
Cross References	System function: R3.7, R4.2, R4.3, R4.4, R4.7 Use case: Dictionary, Explain Word, Print Picture, Play Sound, Search Word
Pre-Requisites	Child Mode를 실행한다.
Typical Courses of Events	(C): Child / (S): System 1. (C) btnDictionary 클릭 2. (C) txtWord에 단어를 입력 받는다. 3. (S) searchWord(newWord)로 Word 객체를 할당 받는다. 4. (S) explainWord(), printPicture() 실행 5. (C) btnSound 클릭 6. (S) playSound URL경로를 들어가 파일재생 7. (S) 2로 돌아감
Alternative Courses of Events	2. btnExit 클릭 시 Child mode로 돌아감 5. btnSound 클릭하지 않으면 7. 생략
Exceptional Course of Events	3. 입력한 단어가 없을 시 찾을 수 없다며 메시지 출력 및 상태유지

Use Case	Print Wordlist
Actor	N/A
Purpose	어떤 알파벳으로 시작하는 단어 3개를 찾는다
Overview	알파벳으로 시작하는 단어 3개를 랜덤 하게 찾아준다.
Type	Primary and Real
Cross References	System function: R4.1, R4.7 Use case: Print WordList, Search Word
Pre-Requisites	Wordtrain Practice실행
Typical Courses of Events	(S): System 1. (S) wordTrainPractice도중 요청 2. (S) alphabet=Random()*26 생성 3. (S) searchWordList(WordList, alphabet)실행 4. (S) 찾은 단어 중 랜덤하게 3개를 선택해 WordList 반환
Alternative Courses of Events	N/A
Exceptional Course of Events	3. 입력한 알파벳이 3개미만이면, 3개중 못 찾은 단어는 -1로 대체.

Use Case	Explain Word
Actor	N/A
Purpose	단어의 간단한 설명을 출력한다.
Overview	검색한 단어의 간단한 설명을 text로 출력한다.
Type	Primary and Real
Cross References	System function: R4.2 Use case: Explain Word
Pre-Requisites	Word 객체 생성
Typical Courses of Events	(S): System 1. (S) Word.getInformation()로 Word.information을 받아옴 2. (S) txtExplain.setText(Word.getInformation())으로 설정
Alternative Courses of Events	N/A
Exceptional Course of Events	N/A

Use Case	Print Picture
Actor	N/A
Purpose	단어의 사진을 출력한다.
Overview	검색한 단어의 사진을 출력한다.
Type	Primary and Real
Cross References	System function: R4.3 Use case: Print Picture
Pre-Requisites	Word객체 생성
Typical Courses of Events	(S): System 1. (S) Word.getPicture()로 Word.picture을 받아옴 2. (S) lblPicture.setIcon(Word.getPicture())으로 설정
Alternative Courses of Events	N/A
Exceptional Course of Events	N/A

Use Case	Play Sound
Actor	Child
Purpose	단어의 발음을 재생한다.
Overview	검색한 단어의 소리를 재생한다.
Type	Primary and Real
Cross References	System function: R4.4 Use case: Play Sound
Pre-Requisites	Word객체 생성
Typical Courses of Events	(C): Child (S): System 1. (C) btnSound 클릭 2. (S) Word.getSound()로 저장된 경로를 받아와 파일을 재생
Alternative Courses of Events	N/A
Exceptional Course of Events	N/A

Use Case	Check Word
Actor	N/A
Purpose	끝말잇기가 이어지는지 확인한다.
Overview	주어진 단어 두 개로 끝말잇기가 이어지는지 확인한다.
Type	Primary and Real
Cross References	System function: R4.6 Use case: Check Word
Pre-Requisites	Word 객체 생성
Typical Courses of Events	(S): System 1. (S) Wordtrain 마지막에 저장된 String 의 마지막 알파벳과 현재 입력한 단어의 첫 알파벳을 비교 2. (S) 일치 여부 결과반환
Alternative Courses of Events	N/A
Exceptional Course of Events	N/A



Use Case	Search Word
Actor	Child
Purpose	입력한 단어를 검색한다.
Overview	입력한 단어를 검색해 존재한다면 해당하는 Word객체를 생성한다.
Type	Primary and Real
Cross References	System function: R4.7 Use case: Search Word
Pre-Requisites	Wordtrain, Dictionary 실행
Typical Courses of Events	(C): Child (S): System 1. (C) txtWord에서 검색을 원하는 단어를 입력 2. (S) Word.txt 파일을 검색 3. (S) Word객체를 생성해서 Word.information, Word.picture, Word.Sound를 각각 이름, 설명, 이미지, 발음 등을 할당한다
Alternative Courses of Events	2. 단어가 존재 하지 않는다면, -1반환.
Exceptional Course of Events	N/A

## Activity 2042. Define Reports, UI, and Storyboards

### Main

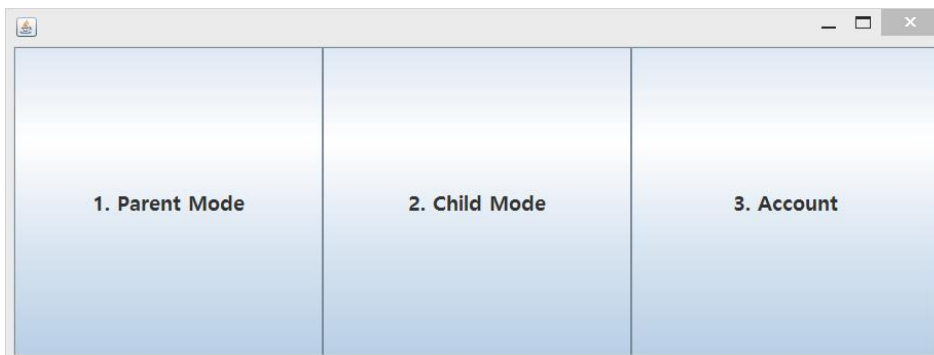

### Account

A screenshot of an account creation form window. The window has a title bar with a minimize, maximize, and close button. The main content area is light gray and contains two text input fields. The first field is labeled '아이 이름' (Child Name) and the second is labeled '부모님 비밀번호' (Parent Password). Below the fields is a blue button labeled '설정' (Settings).

## Parent Mode

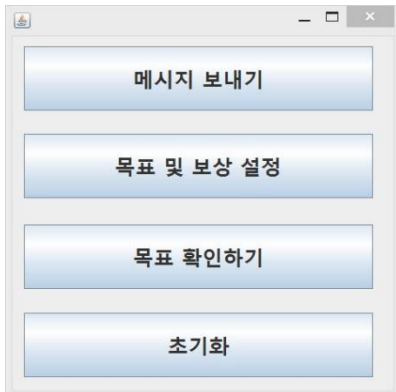

## Send Message

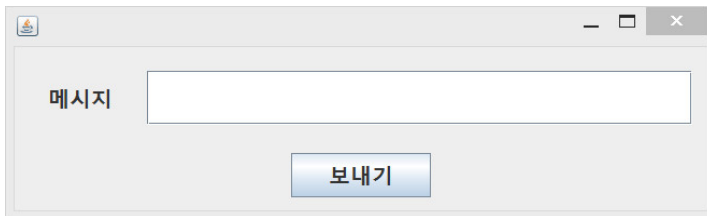

## Goal Setting

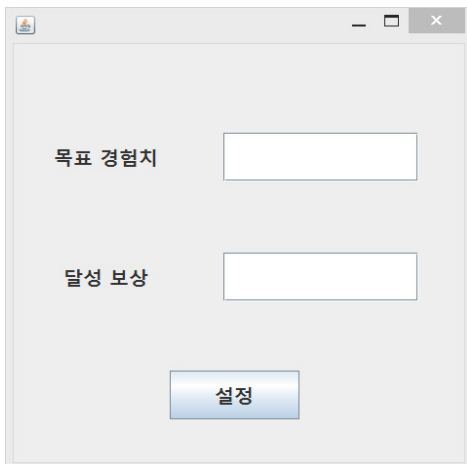

## Check Goal

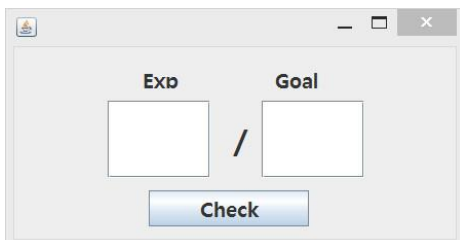

## Child Mode



## Wordtrain Practice

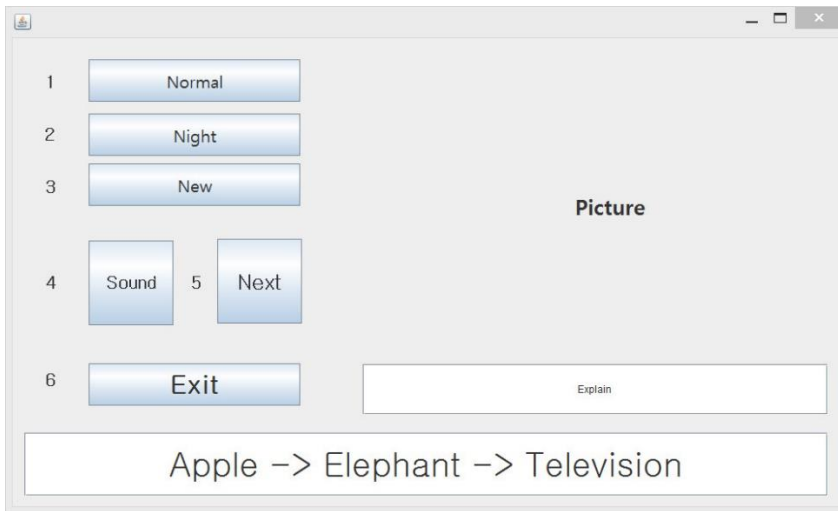

## Wordtrain Game

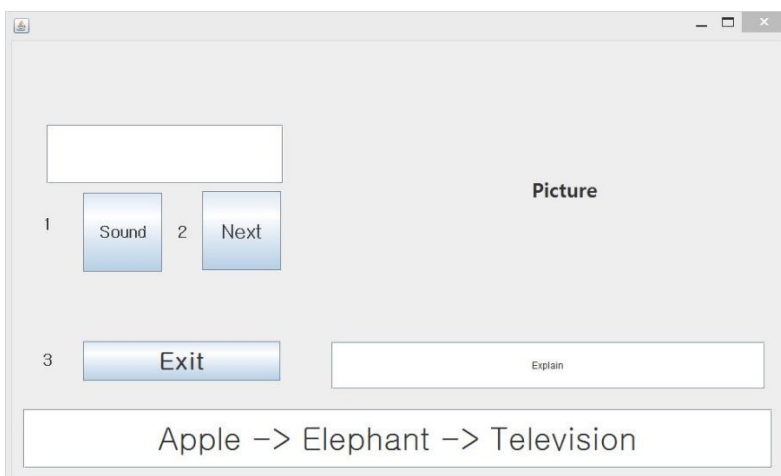

## Dictionary

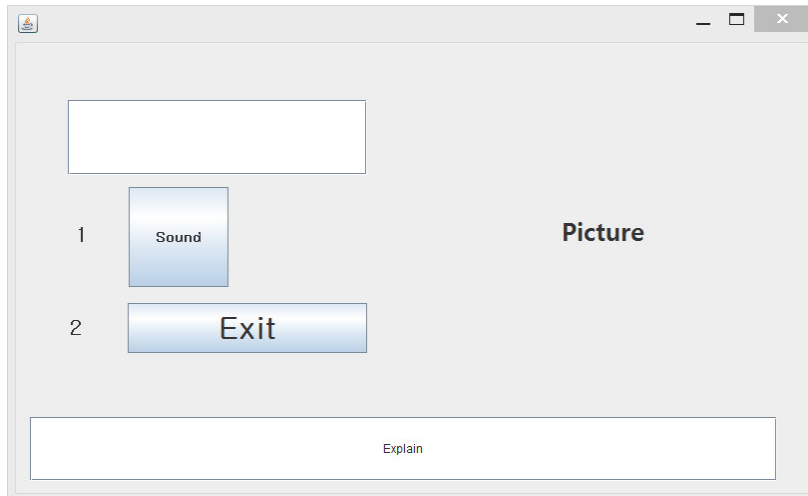

## Activity 2043. Refine System Architecture

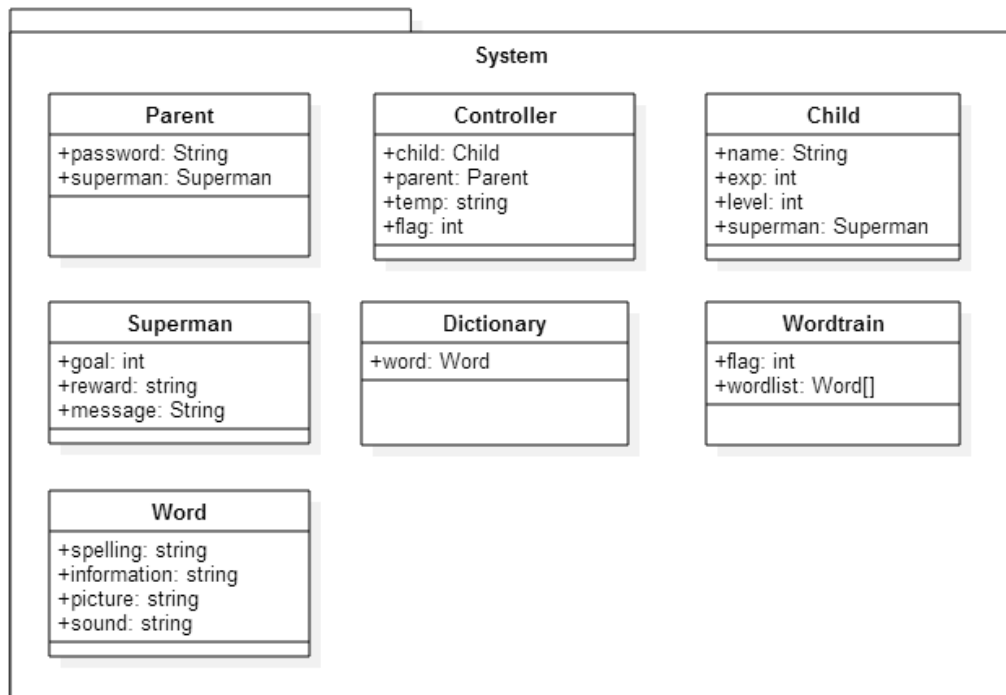

# Activity 2044. Define Interaction Diagrams

## Parent Mode

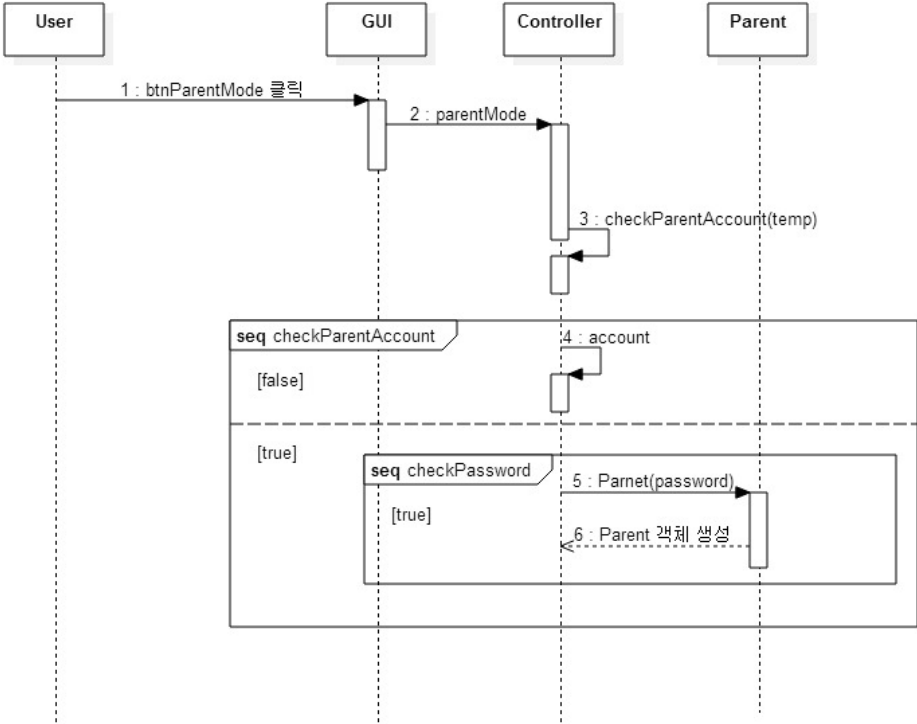

## Account

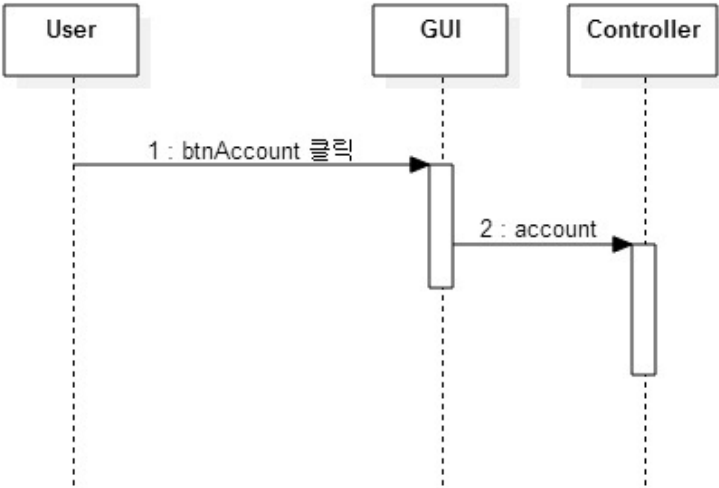

Send Message

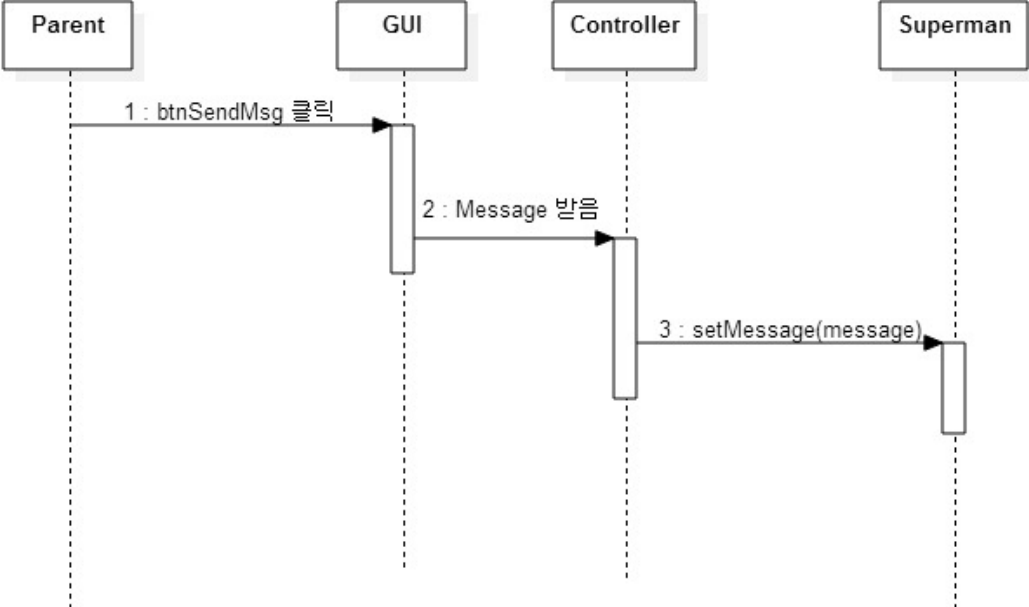

Goal Setting

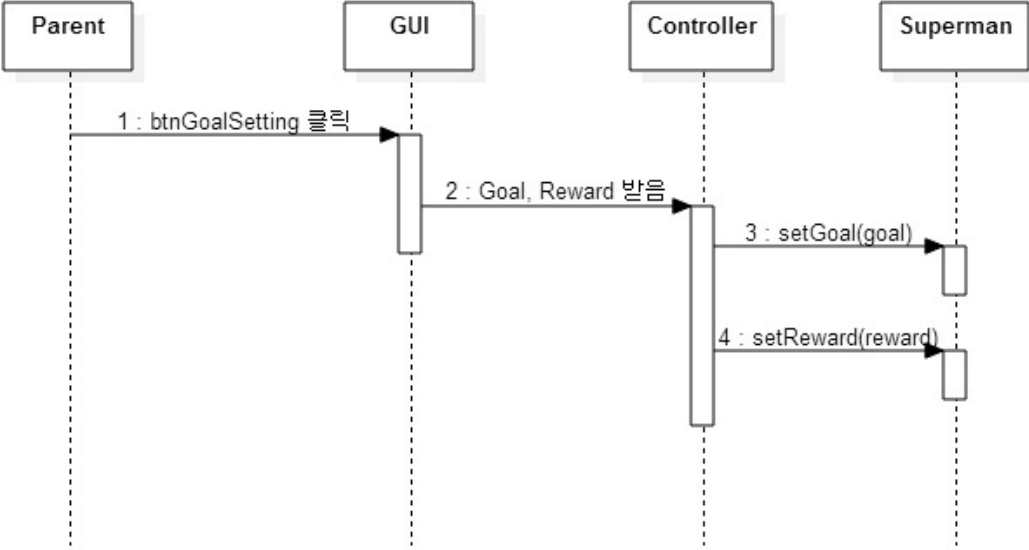

## Check Goal

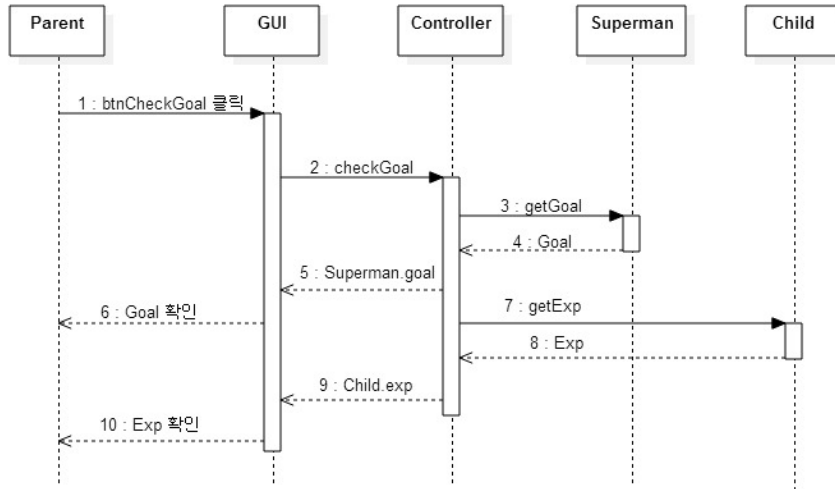

## Reset

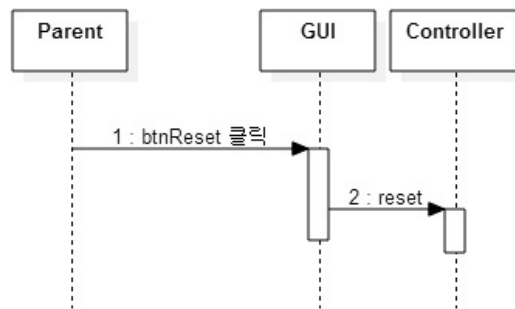

## Child Mode

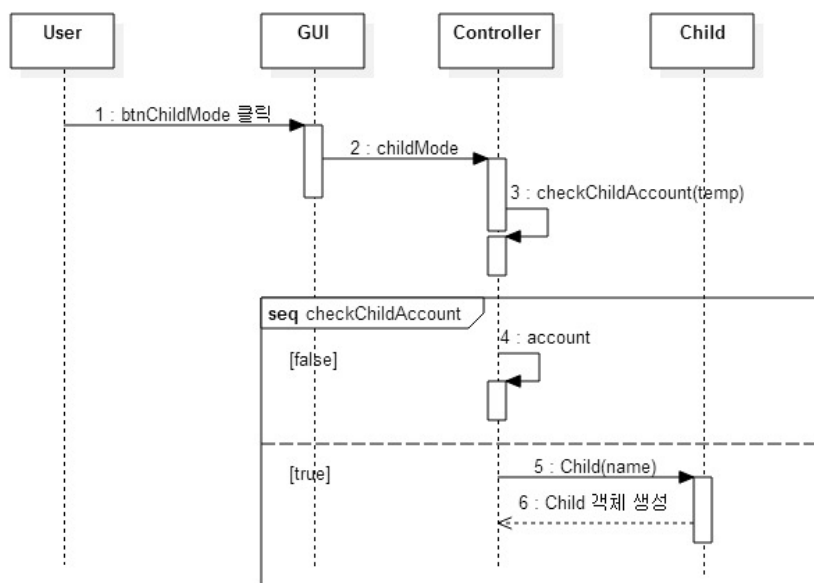

### Print Message

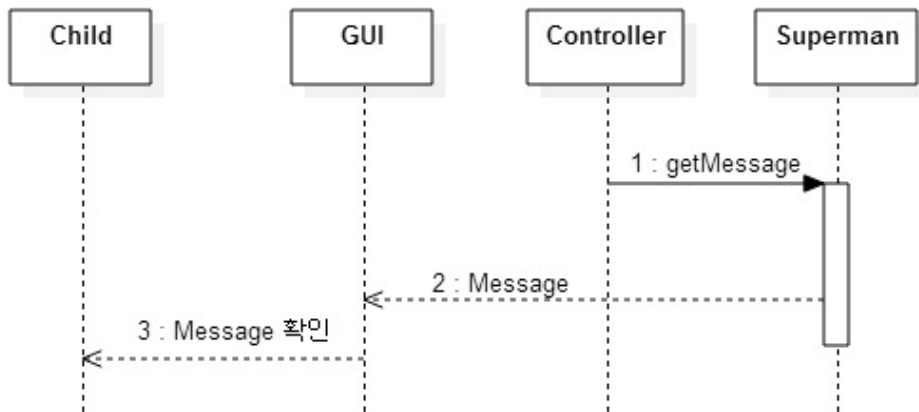

### Print Goal

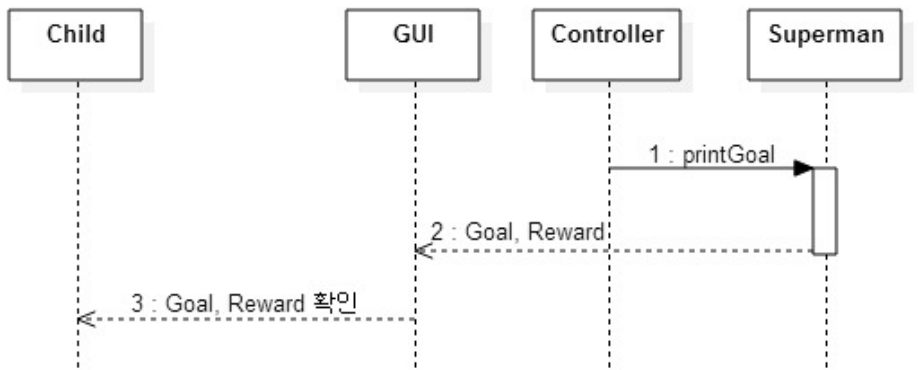

### Print Exp

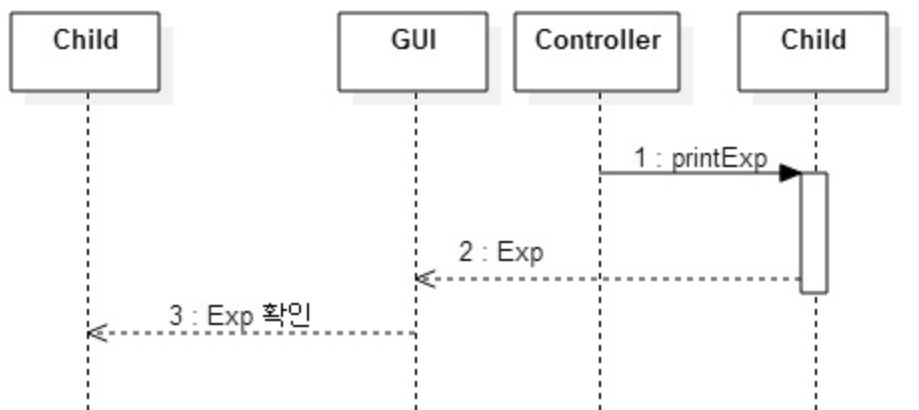



## Next Level

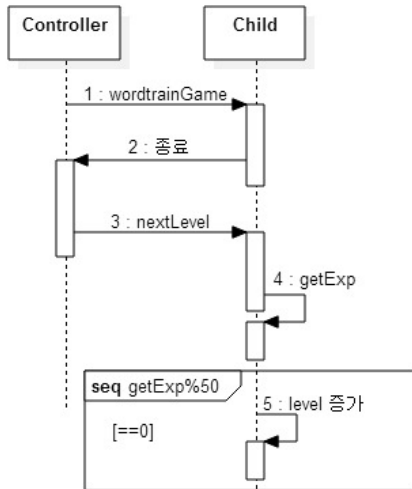

## Wordtrain Practice

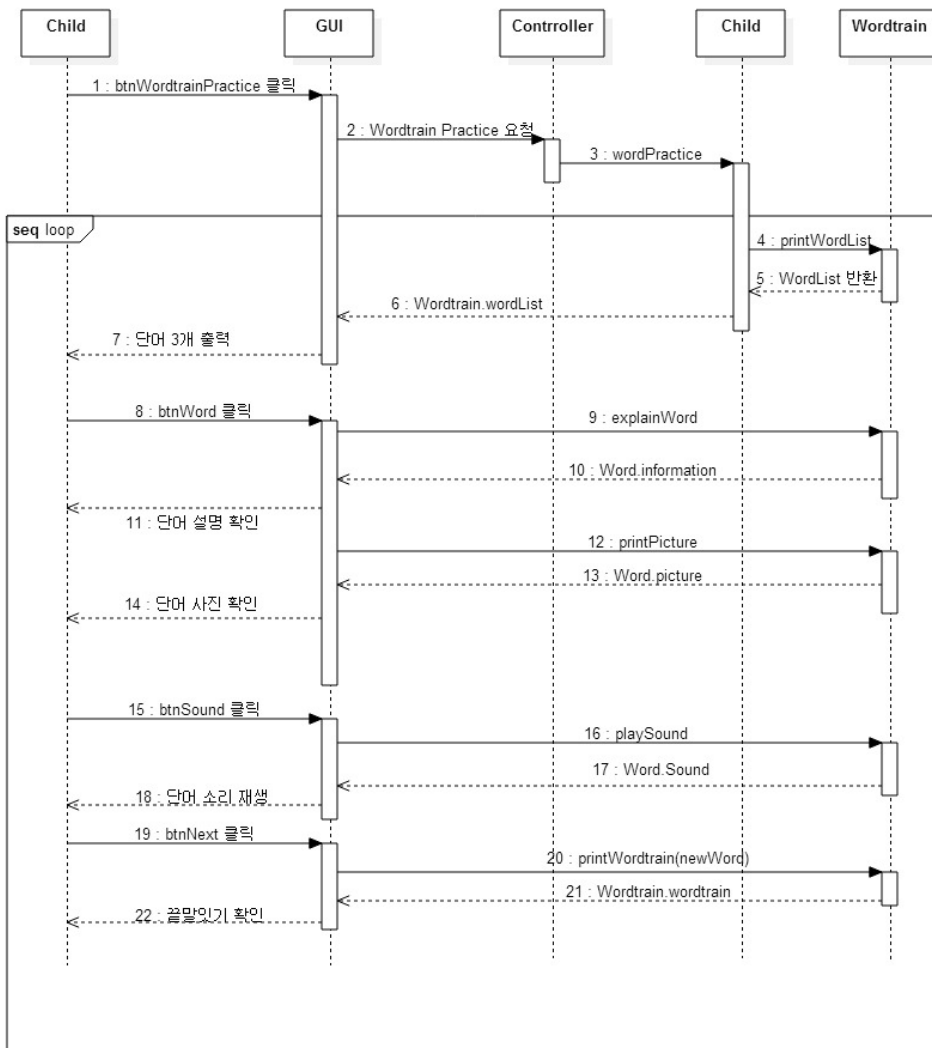

# Wordtrain Game

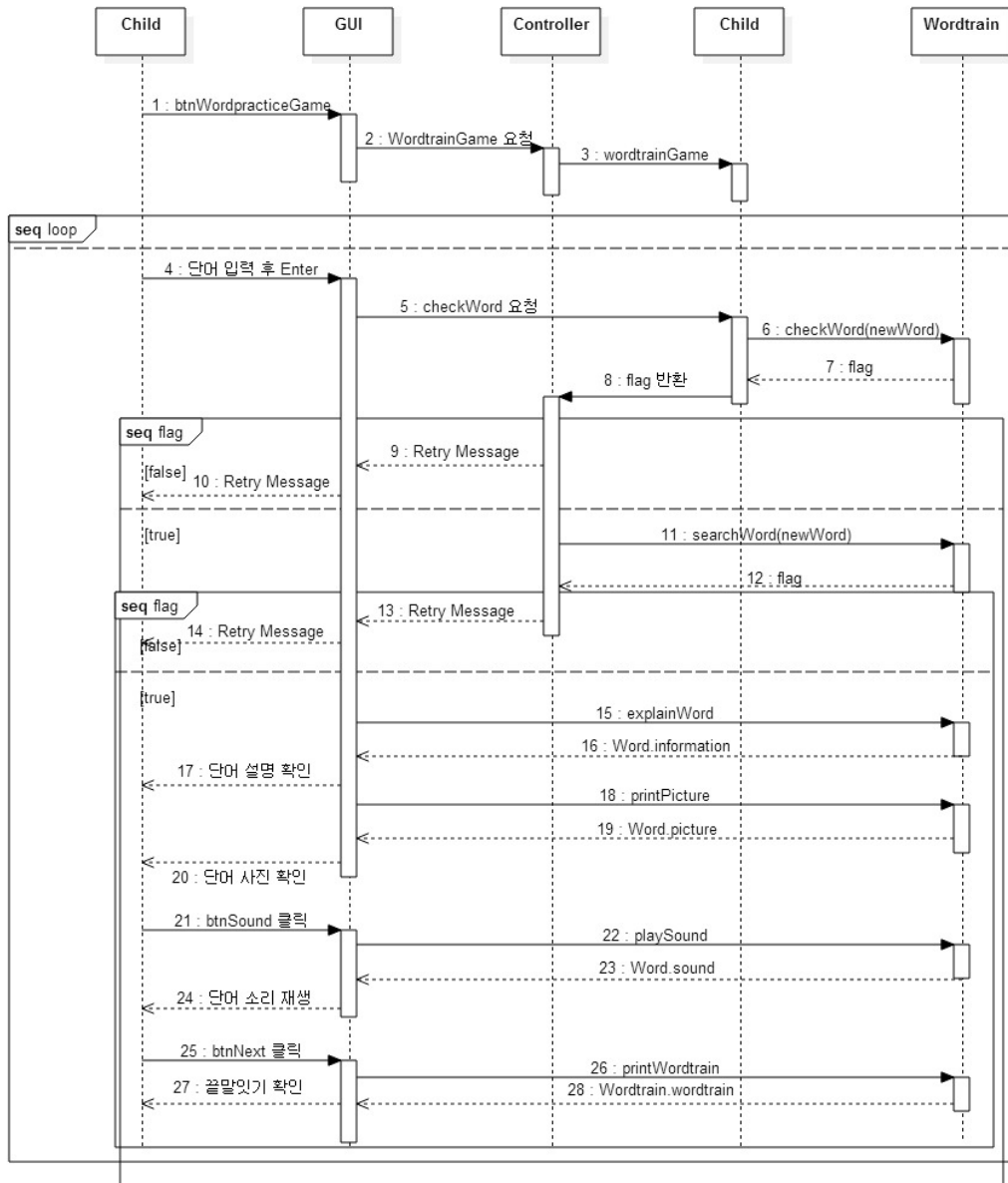

## Dictionary

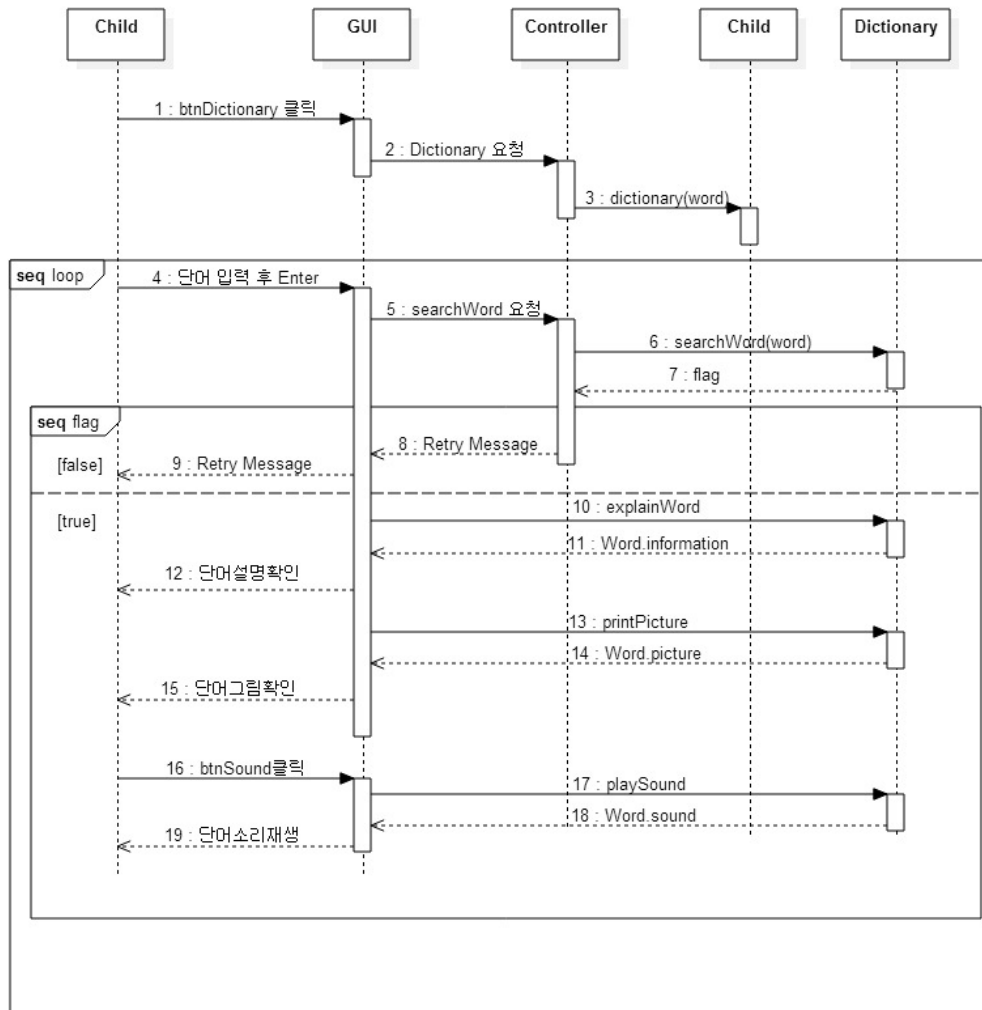

## Print WordList

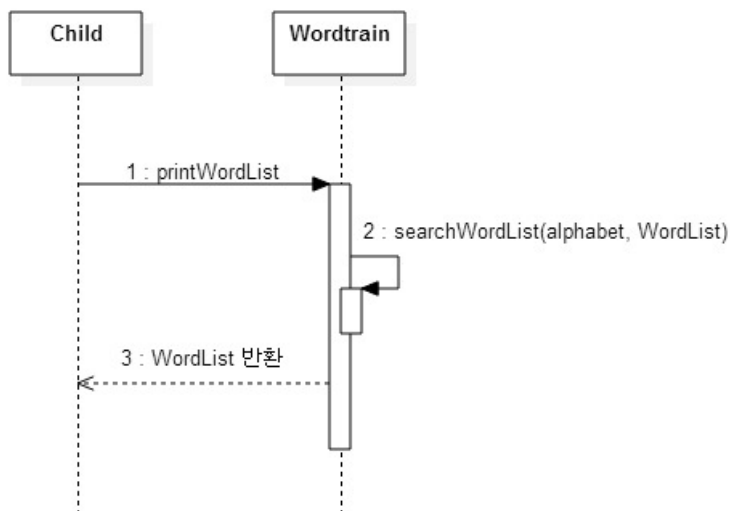

### Explain Word

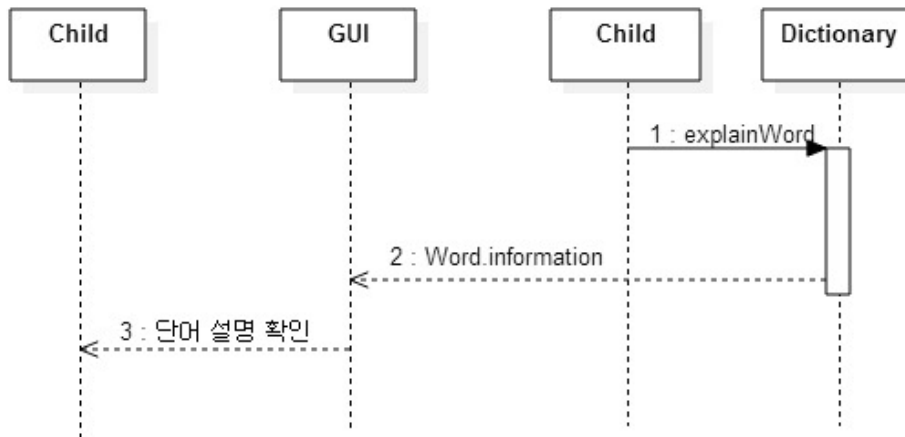

### Print Picture

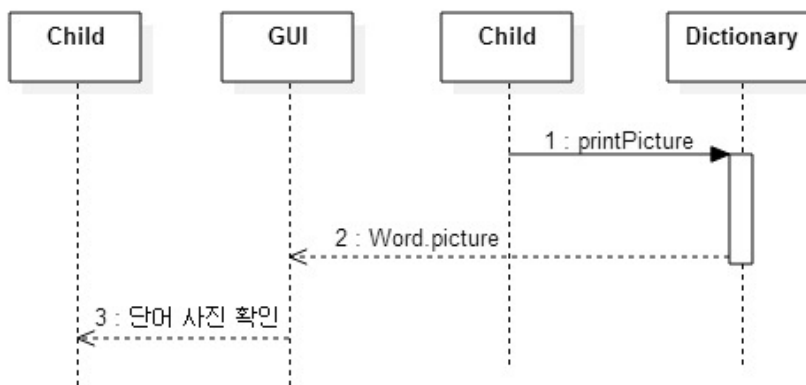

### Play Sound

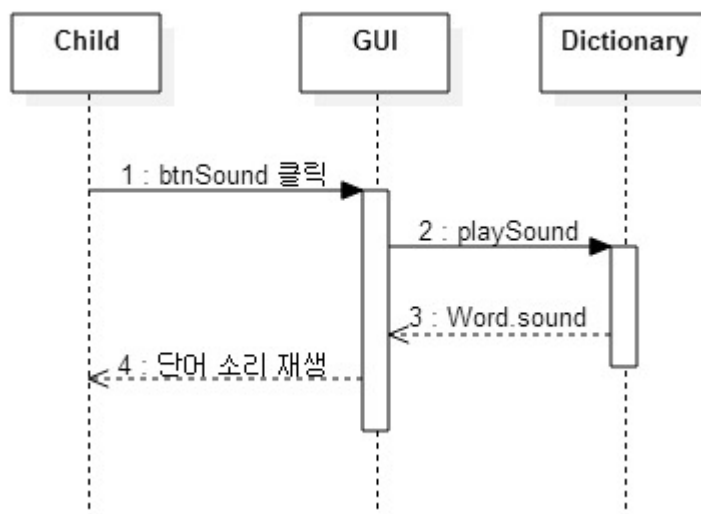

### Print Wordtrain

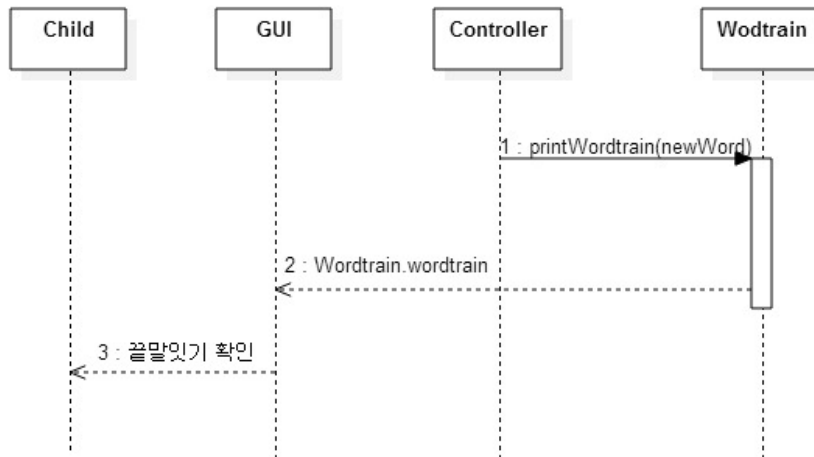

### Check Word

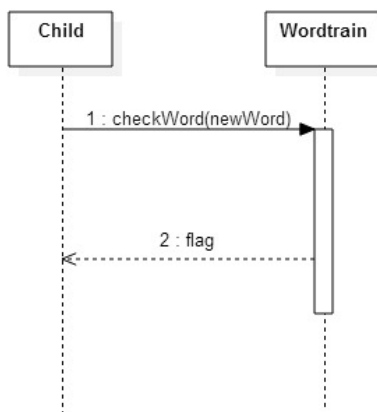

### Search Word

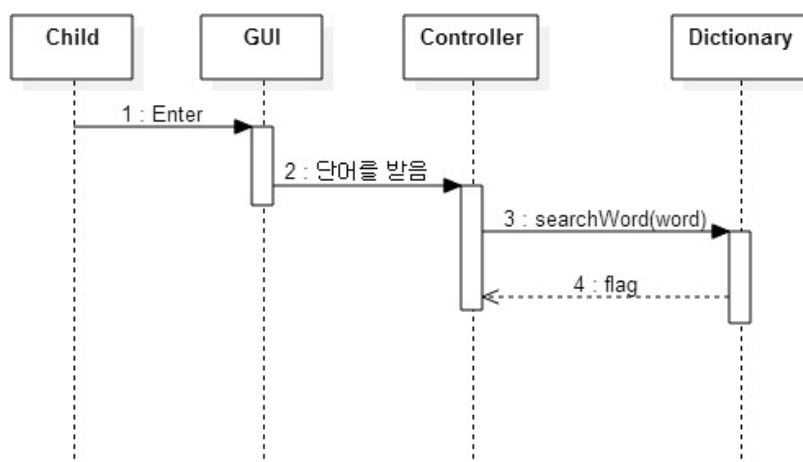

# Activity 2045. Define Design Class Diagrams

